

Air Humidification Practice

• Colonial Printing Company, Warwick, Rhode Island •

A Job Worth Doing...



DRAABE TurboFog 16

Optimum Air Humidity in the Pressroom

...is worth doing extraordinarily well. This motto has provided Colonial with the dedication needed to become one of the most successful printers in Rhode Island. Optimum air humidity serves to ensure a trouble-free production process.

During the past several years, Colonial Printing has increased its profile even further by spending



Ray Menna (r.) and Wafik Kouchouk, DRAABE Sales Director, have forged an excellent partnership

additional money on state-of-the-art proofing systems and large-format printing. Colonial's customers – a mix of ad agencies and corporate end-users – have responded accordingly, giving the printer an

array of work from simple one-color business cards to complex full-color annual reports. It was time to move the firm to larger headquarters to adequately handle the size of the new equipment and increased work volume.

Lack of Humidification

"When we moved to our new facility, we installed more presses to give us higher capacity," says Ray Menna, president of Colonial Printing. "What we didn't expect were the problems incurred by all of

this equipment running two shifts a day. We started to see humidification problems, such as paper cracking, curl, and static that we had never encountered in our old facility. We knew we had to humidify."

No paper curl and static

Ray Menna decided to install the high-pressure DRAABE TurboFog system: "We felt that TurboFog would provide us with lower energy consumption than compressed air or steam systems, and we were quite impressed with the drip free atomization of the titanium nozzles." Menna also liked DRAABE's rental system approach, in which Colonial would be renting the water treatment and high-pressure pump with an automatic half-yearly exchange for servicing and maintenance. "By renting the system, we're kept free from any maintenance work on the systems. DRAABE is the expert in water technology and guarantees us a hygienic, worry-free operation with unlimited warranty."



DRAABE Service Container

Since the installation, Colonial Printing has completely eliminated its paper curl, cracking, and static. "The quality of the DRAABE product is excellent and the professional consultation left no question unanswered," emphasize Menna.

Air Humidification Practice

DRAABE High-Pressure Humidification TurboFog

• Colonial Printing Company, Warwick, Rhode Island •

System schematic

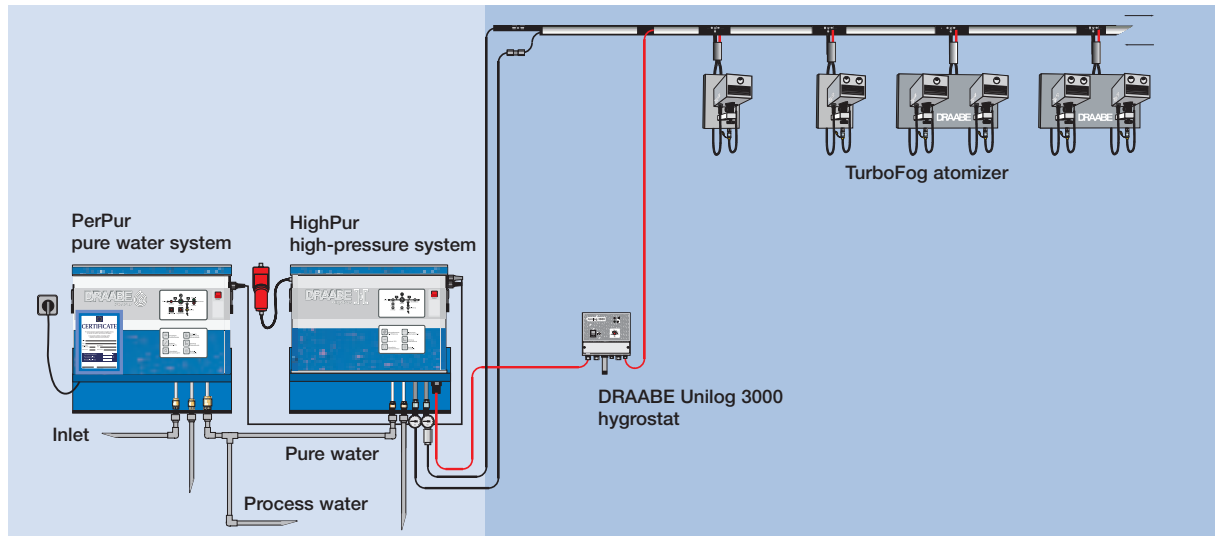

Pure-water System:

1 DRAABE PerPur 2122

High-pressure System:

1 DRAABE HighPur 202

Application/ Nozzle System:

Pressroom, finishing:
6 DRAABE TurboFog 16

Room Volume:

26,000 ft³

Humidity Required:

50% relative humidity

Installation:

November 2005

Benefits of Air Humidification:

- Faster production
- Eliminates paper curl
- No static buildup
- Reduces spoilage and dust
- Higher register accuracy
- Consistent quality
- Comfortable room climate

Benefits of the DRAABE Full-Service Rental Agreement:

- Exchange of the system container every 6 months
- Maintenance and disinfection
- 100% hygienic
- Total operating safety
- Unlimited warranty
- Automatic upgrades

Canada:
DRAABE
A division of AxAir Nortec Ltd.
2740 Fenton Road
Ottawa, Ontario K1T 3T7
Phone: (613) 822-0335
www.draabe.com

USA:
DRAABE
A division of AxAir Nortec Inc.
826 Proctor Ave.
Ogdensburg, New York 13669
Phone: (315) 425-1255
www.draabe.com

DRAABE
a WMH Company